

**FORD 250**  
*Bargain Priced Automatic Twine-Tie*

# HAY BALERS

Choose From  
PTO and  
Engine Models



## **ECONOMICAL** for smaller hay acreages

Now you don't have to be a big hay grower in order to make an automatic hay baler pay for itself on your farm. The Ford 250 Hay Baler can be a profitable investment for the man who has smaller acreages of hay. Low first cost, together with low operating and maintenance costs make this baler practical on many farms that have previously not baled their hay or had to rely on the availability of a custom operator. This PTO baler is efficient behind most 2-plow tractors. The engine model operates efficiently in exceptionally heavy hay or under hilly conditions.

### **Timely Baling — Better Quality**

By owning your own baler you can put up your hay at just the right time to preserve its maximum feeding value. There's no waiting your turn — often at the expense of lower quality hay which means dollars out of your pocket.

### **Good Capacity — Dependable**

With this baler you can bale up to 7 tons of hay per hour, or 4 bales per minute. Operation is easy and dependable, and sturdy construction means long life and low upkeep cost.



All Ford Equipment is designed and built to exceptionally high quality standards. Each implement is matched to the Ford Tractor; thoroughly tested by Ford Implement Specialists. Whatever your equipment needs, investigate Ford Equipment first. See your nearby Ford Tractor and Implement Dealer.

# KEEPS BALING COSTS DOWN—

## Compact and li

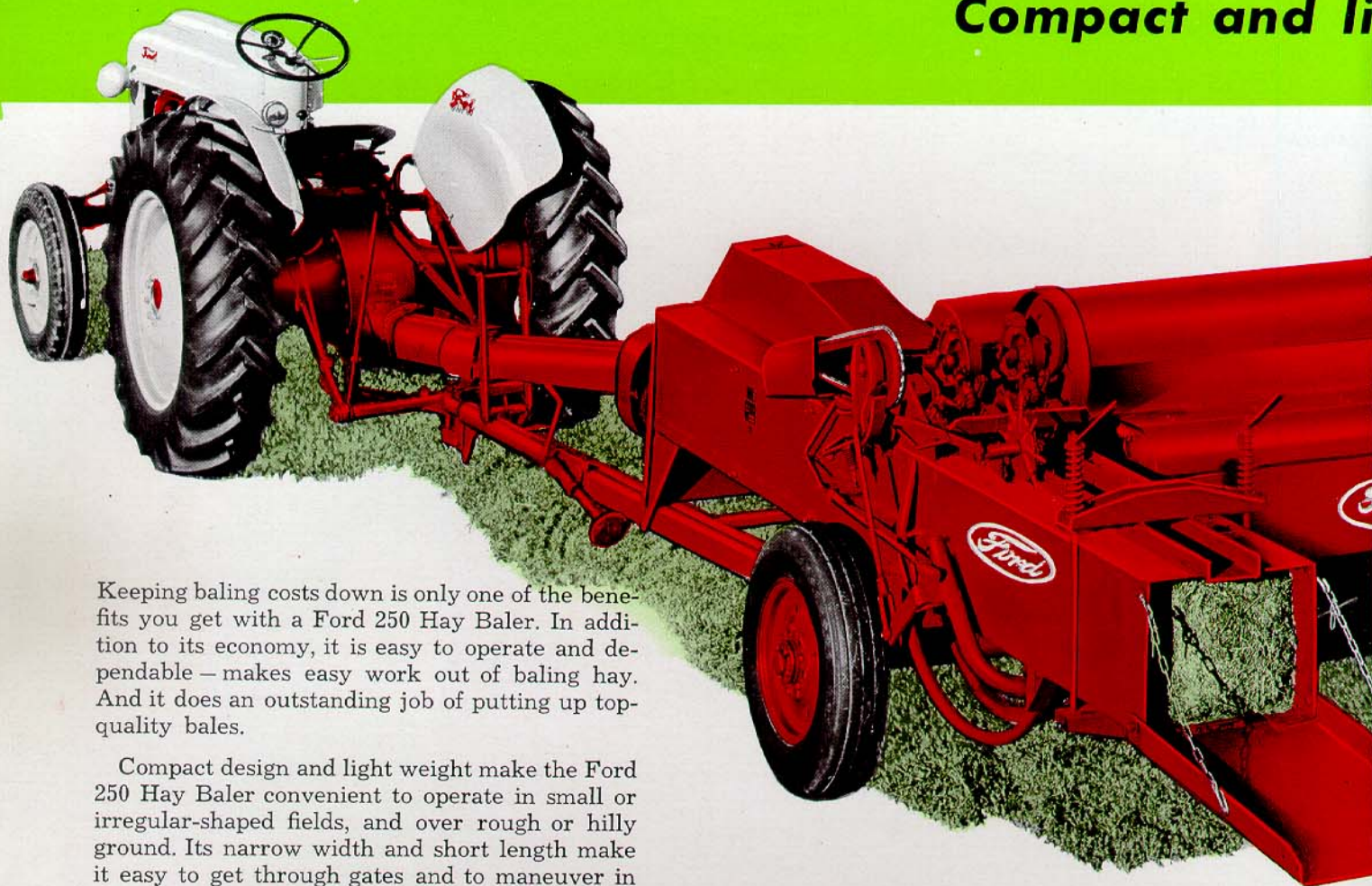

Keeping baling costs down is only one of the benefits you get with a Ford 250 Hay Baler. In addition to its economy, it is easy to operate and dependable—makes easy work out of baling hay. And it does an outstanding job of putting up top-quality bales.

Compact design and light weight make the Ford 250 Hay Baler convenient to operate in small or irregular-shaped fields, and over rough or hilly ground. Its narrow width and short length make it easy to get through gates and to maneuver in close places. And it occupies less storage space.

There are many outstanding features in this baler which help to provide excellent performance. Simple design, modern slip clutches and fewer working parts make it easy to maintain, adjust and service. This can mean a substantial saving in both time and money, and at the same time result in more and better-made bales of hay. All parts are accurately made for more efficient operation and longer life.

**You can be sure of getting UNIFORM, WELL MADE BALES**



Ford 250 Hay Balers make smooth, firmly packed bales that are uniform in size and weight—and they are tied securely for easy handling and storage. When opened, the bales come apart in sections for easy feeding.

**FORD 250 HAY BALER**

with *engine drive*

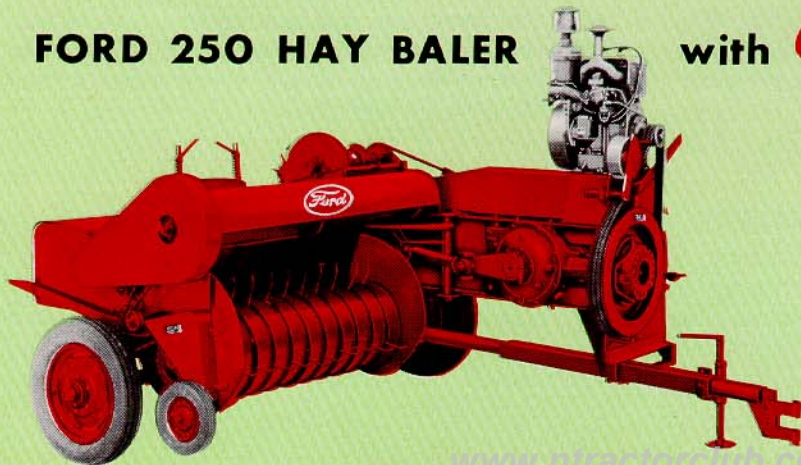

Smooth, efficient and dependable power for this baler is provided with a rugged 15 horsepower engine. You can count on it to keep the baler operating at the right speed for efficient baling . . . in heavy crops and over hills. This engine has a low fuel consumption, low maintenance costs and long life. Available with or without electric starter.

# QUALITY AND EFFICIENCY UP light in weight for easy maneuverability

*has many outstanding features*  
to help you do a better job

- **SAFETY HEAD LOCK**  
— reduces needle breakage
- **SIX POSITIVE ACTION BALE DOGS**  
— help assure tight bales
- **SEALED HEAVY DUTY GEARS**  
— keep out dust, run in oil
- **4-BALL TWINE CAN**  
— ties about 1000 bales
- **LARGE FEED OPENING**  
— has big capacity, saves leaves
- **Generous use of ANTI-FRICTION BEARINGS**

## FLYWHEEL SLIP CLUTCH

The flywheel slip clutch is an outstanding feature on Ford 250 Hay Balers. It gives positive protection to the gears, connecting rod and plunger and improves the performance and capacity of the baler. Faster baling and easier, more convenient operation result from eliminating stops to replace shear pins. Less shock and overload on gears provide for longer baler life with less maintenance.

**PICK-UP** is full floating. Gauge wheel guides it smoothly over uneven ground, letting the curved pickup fingers get all the hay. It is power driven—provides better control for more uniform feeding.

**AUGER AND SWEEP FORK** give fast, positive feeding of material into bale chamber—keep it moving steadily. Solid bottom of auger housing prevents loose leaves from being lost—saves them for added feed value in hay.

**KNOTTERS** tie dependable knots that stay tied. They work well under a wide range of conditions because twine fingers reduce strain on knotters by helping hold the twine while the knots are being securely formed.

**METERING WHEEL** measures either 36 or 42 inch bale lengths, then trips the needles to start operation of the knotter mechanism. It also operates the bale counter to keep you informed of the number of bales produced.

**BALE TENSION BARS** help to maintain tight, well shaped bales of uniform weight throughout the field. Under most conditions, they help to control bale weight even where there are thin or heavy spots in the windows.

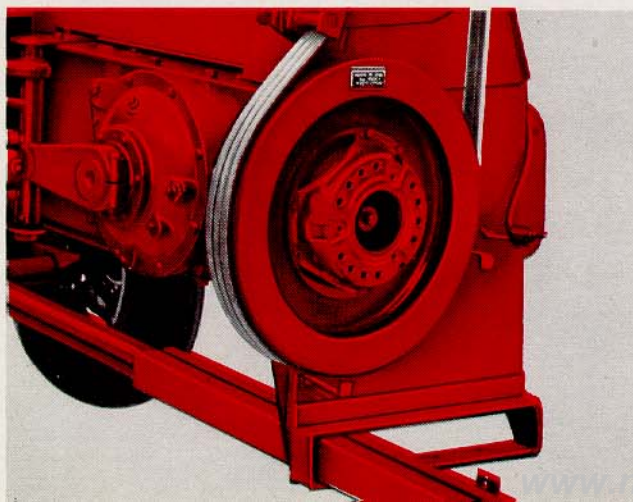
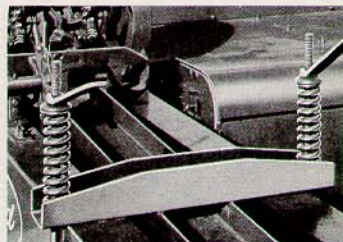
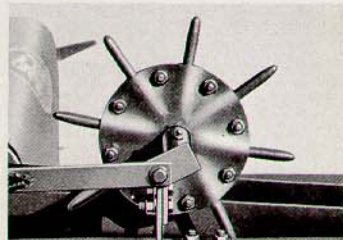
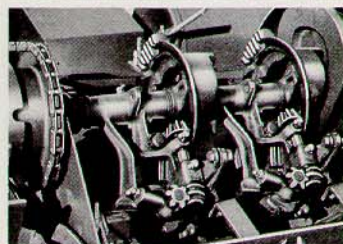
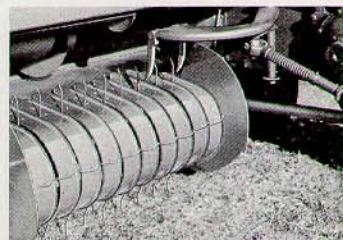
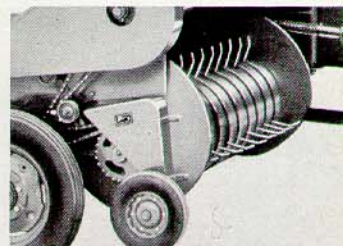

*Design, materials and/or specifications are subject to change without notice and without liability therefor.*



# Specifications

## FORD 250 Hay Balers

Model 14-71 — Engine Drive W/ electric starter

Model 14-76 — Engine Drive L/ electric starter

Model 14-80 — PTO Drive

**Over-all Length**, 15' 10" tail gate down — 14' 2" tail gate up — **Width**, 8' 5" — **Height**, 6' 5" engine model — 4' 3½" (approx.) PTO Model — **Wheel Tread**, 7' 10" — **Weight**, 2570 lbs. engine model — 2400 lbs. (approx.) PTO model — **Bale Chamber**, 14" x 18" — **Bale Lengths**, 36" or 42" — **Pick-up Width**, 47½ — **Pick-up Speed** 57½ rpm — **Tooth Bars**, 4 — **Teeth**, 20 pairs — **Plunger Speed**, 68-70 strokes per min. — **Tire Sizes**, Left 6.70 x 15 — Right 5.00 x 15.

**ADJUSTABLE HITCH AND STAND** make operation easy. The 3-position tongue makes it possible to operate the baler offset or straight behind for transport. A built-in jack holds tongue at right height when disconnected from tractor.

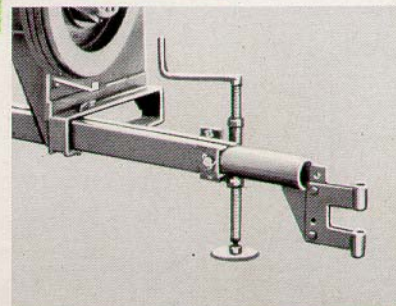

**BALE COUNTER** tells you at a glance just how many bales you've made — makes it easy to keep informed on your progress at all times. There's no trouble keeping track of a day's work or the results of an entire job.



# FORD TRACTOR AND EQUIPMENT SALES COMPANY OF CANADA

LIMITED

SAINT JOHN, MONTREAL, TORONTO, WINNIPEG, REGINA, CALGARY, VANCOUVER

[www.ntractorclub.com](http://www.ntractorclub.com)